

不鏽鋼專用立銼刀
For Stainless Steels
Square End Mills



型號 / Order No.	直徑 Diameter D1	刃長 Flute Length L1	全長 O.A.L. L2	柄徑 Shank Dia D2
USSP 0306	3.0	8	50	6
USSP 0406	4.0	11	50	6
USSP 0506	5.0	13	50	6
USSP 0606	6.0	16	50	6
USSP 0808	8.0	20	60	8
USSP 1010	10.0	25	75	10
USSP 1212	12.0	30	75	12
USSP 1616	16.0	40	100	16
USSP 2020	20.0	45	100	20

unit: mm



ALUMINUM ALLOY CUTTING SERIES

鋁合金材料加工系列



MG

AB

鋁用圓頭立銼刀
Ball Nose End Mills

型號 / Order No.	半徑 Radius R	刃長 Flute Length L1	全長 O.A.L. L2	柄徑 Shank Dia D2
AB 0104	R0.5	3	50	4
AB 0154	R0.75	4	50	4
AB 0204	R1	6	50	4
AB 0303	R1.5	6	50	3
AB 0404	R2	8	50	4
AB 0606	R3	12	50	6
AB 0808	R4	16	60	8
AB 1010	R5	20	75	10
AB 1212	R6	24	75	12

unit: mm

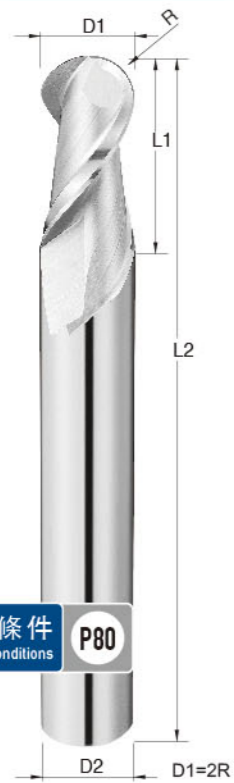
切削條件
Cutting Conditions

P80

UMG

ASA-2F

鋁用立銼刀
Square End Mills

型號 / Order No.	直徑 Diameter D1	刃長 Flute Length L1	全長 O.A.L. L2	柄徑 Shank Dia D2
ASA 20106	1.0	3	50	6
ASA 20206	2.0	6	50	6
ASA 20306	3.0	9	50	6
ASA 20406	4.0	12	50	6
ASA 20506	5.0	15	50	6
ASA 20606	6.0	18	50	6
ASA 20808	8.0	20	60	8
ASA 21010	10.0	30	75	10
ASA 21212	12.0	30	75	12
ASA 21616	16.0	45	100	16

unit: mm

切削條件
Cutting Conditions

P80

MG

ASA-3F

鋁用立銼刀
Square End Mills

型號 / Order No.	直徑 Diameter D1	刃長 Flute Length L1	全長 O.A.L. L2	柄徑 Shank Dia D2
ASA 30206	2.0	6	50	6
ASA 30306	3.0	9	50	6
ASA 30406	4.0	12	50	6
ASA 30506	5.0	15	50	6
ASA 30606	6.0	18	50	6
ASA 30808	8.0	20	60	8
ASA 31010	10.0	30	75	10
ASA 31212	12.0	30	75	12
ASA 31616	16.0	45	100	16
ASA 32020	20.0	45	100	20

unit: mm

切削條件
Cutting Conditions

P80

MG

ASB-2F

鋁用立銼刀
Square End Mills

型號 / Order No.	直徑 Diameter D1	刃長 Flute Length L1	全長 O.A.L. L2	柄徑 Shank Dia D2
ASB 20106	1.0	3	50	6
ASB 20206	2.0	6	50	6
ASB 20306	3.0	9	50	6
ASB 20406	4.0	12	50	6
ASB 20506	5.0	15	50	6
ASB 20606	6.0	18	50	6
ASB 20808	8.0	20	60	8
ASB 21010	10.0	30	75	10
ASB 21212	12.0	30	75	12
ASB 21616	16.0	45	100	16

unit: mm

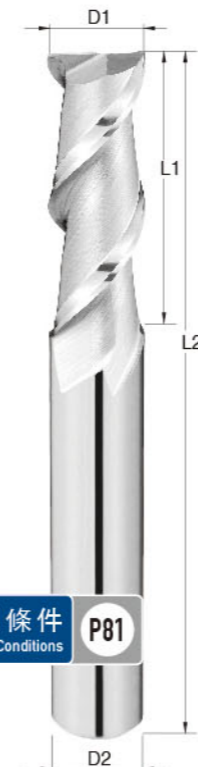
切削條件
Cutting Conditions

P81

MG

ASB-3F

鋁用立銼刀
Square End Mills

型號 / Order No.	直徑 Diameter D1	刃長 Flute Length L1	全長 O.A.L. L2	柄徑 Shank Dia D2
ASB 30206	2.0	6	50	6
ASB 30306	3.0	9	50	6
ASB 30406	4.0	12	50	6
ASB 30506	5.0	15	50	6
ASB 30606	6.0	18	50	6
ASB 30808	8.0	20	60	8
ASB 31010	10.0	30	75	10
ASB 31212	12.0	30	75	12
ASB 31616	16.0	45	100	16
ASB 32020	20.0	45	100	20

unit: mm

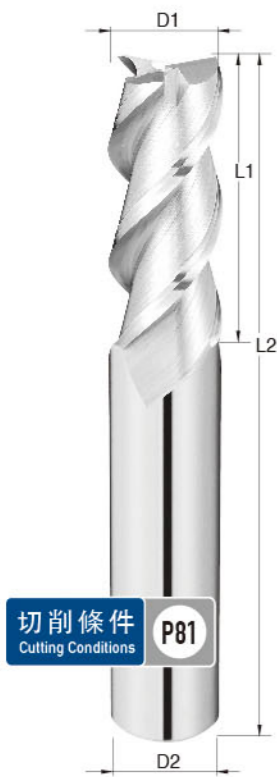
切削條件
Cutting Conditions P81

MG

ASC-3F

鋁用立銼刀
Square End Mills

型號 / Order No.	直徑 Diameter D1	刃長 Flute Length L1	全長 O.A.L. L2	柄徑 Shank Dia D2
ASC 30206	2.0	6	50	6
ASC 30306	3.0	9	50	6
ASC 30406	4.0	12	50	6
ASC 30506	5.0	15	50	6
ASC 30606	6.0	18	50	6
ASC 30808	8.0	24	60	8
ASC 31010	10.0	30	75	10
ASC 31212	12.0	36	75	12
ASC 31616	16.0	45	100	16
ASC 32020	20.0	45	100	20

unit: mm

切削條件
Cutting Conditions P81

MG

ASL

鋁用長刃立銼刀
Long Flute
Square End Mills

型號 / Order No.	直徑 Diameter D1	刃長 Flute Length L1	全長 O.A.L. L2	柄徑 Shank Dia D2
ASL 0206	2.0	9	75	6
ASL 0306	3.0	12	75	6
ASL 0406	4.0	16	75	6
ASL 0506	5.0	20	75	6
ASL 0606	6.0	25	75	6
ASL 0808	8.0	32	75	8
ASL 1010	10.0	50	100	10
ASL 1212	12.0	50	100	12
ASL 1616	16.0	65	150	16
ASL 2020	20.0	75	150	20

unit: mm

切削條件
Cutting Conditions P82

UMG

AR

鋁用圓鼻刀
Corner Radius End Mills

型號 Order No.	直徑 Diameter D1	R角 Corner R R	頸徑 Neck Dia D3	刃長 Flute Length L1	有效長 Effective Length L3	全長 O.A.L. L2	柄徑 Shank Dia D2
AR 0305	3.0	0.5	2.90	6	9	50	6
AR 0405	4.0	0.5	3.88	8	12	50	6
AR 0605	6.0	0.5	5.80	12	18	50	6
AR 0610	6.0	1.0	5.80	12	18	50	6
AR 0805	8.0	0.5	7.70	16	24	60	8
AR 0810	8.0	1.0	7.70	16	24	60	8
AR 1002	10.0	0.2	9.60	20	30	75	10
AR 1005	10.0	0.5	9.60	20	30	75	10
AR 1010	10.0	1.0	9.60	20	30	75	10
AR 1202	12.0	0.2	11.50	24	36	75	12
AR 1205	12.0	0.5	11.50	24	36	75	12
AR 1210	12.0	1.0	11.50	24	36	75	12
AR 1603	16.0	0.3	15.40	30	40	100	16
AR 1605	16.0	0.5	15.40	30	40	100	16
AR 1610	16.0	1.0	15.40	30	40	100	16
AR 1630	16.0	3.0	15.40	30	40	100	16

unit: mm

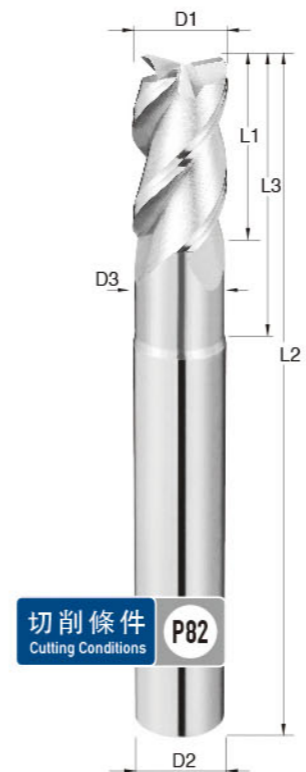
切削條件
Cutting Conditions P82